

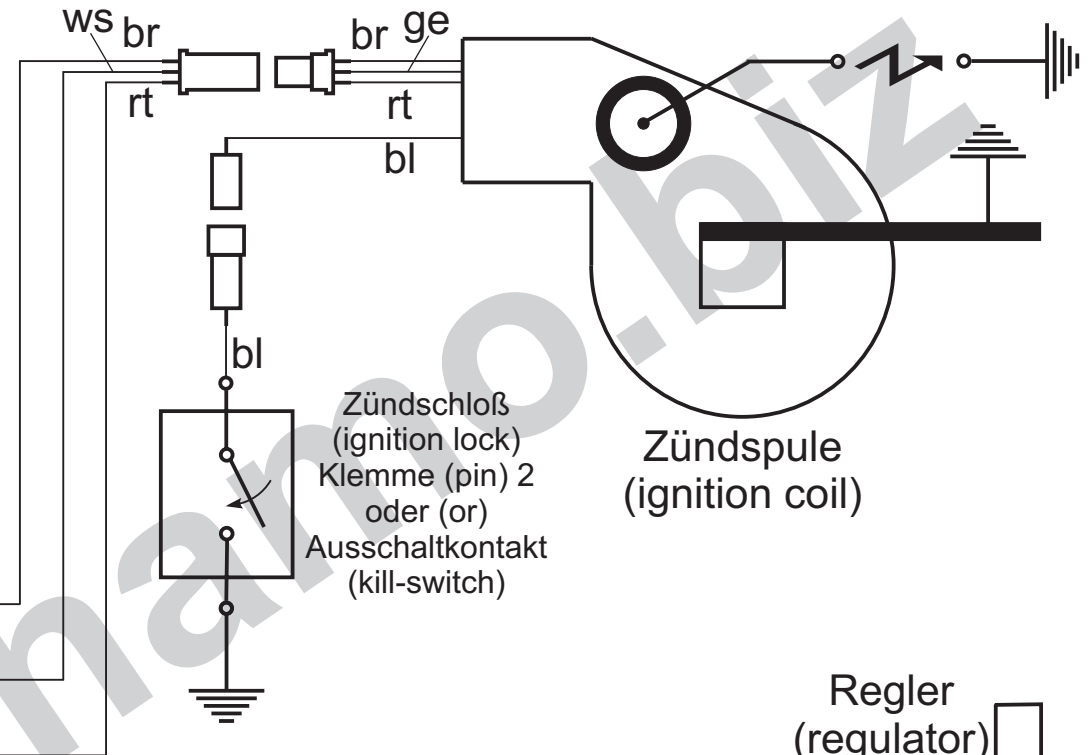

Schaltplan 73ik102 (wiring diagram)

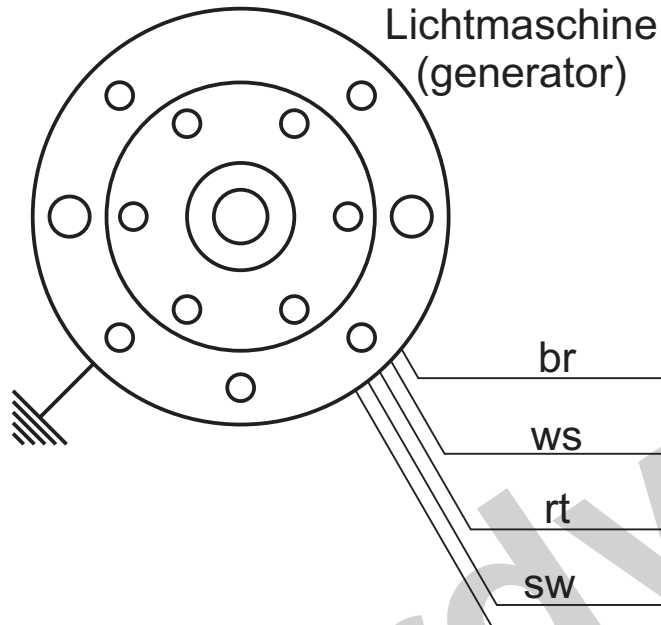

- Kabelfarben
(wiring colours):
- bl = blau (blue)
 - br = braun (brown)
 - ge = gelb (yellow)
 - gn = grün (green)
 - gr = grau (grey)
 - rt = rot (red)
 - sw = schwarz (black)
 - ws = weiß (white)

