

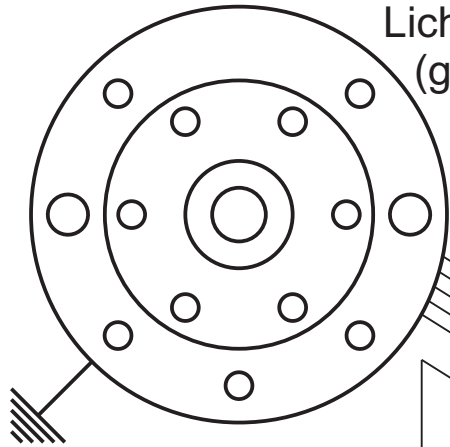

Schaltplan 73mz (wiring diagram)



Lichtmaschine
(generator)

Leerlaufschalter
(neutral switch)

Leerlaufkontr.
(neutral light)

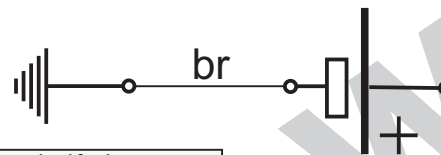

Batterie
(battery)

15 Ampere
Sicherung
(fuse)

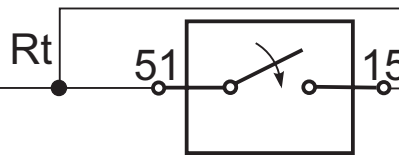

Zündschloß
(ignition lock)

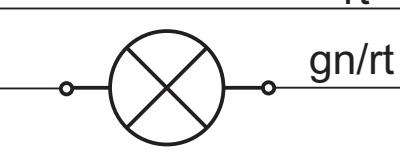

Ladekontrolle
(charge control)
nur (only) 12V

Bordnetz
(existing electric system)

Zündspule
(ignition coil)

Relais
(relay)

Regler
(regulator)

- Kabelfarben**
(wiring colours):
- bl = blau (blue)
 - br = braun (brown)
 - ge = gelb (yellow)
 - gn = grün (green)
 - gr = grau (grey)
 - rt = rot (red)
 - sw = schwarz (black)
 - ws = weiß (white)

