

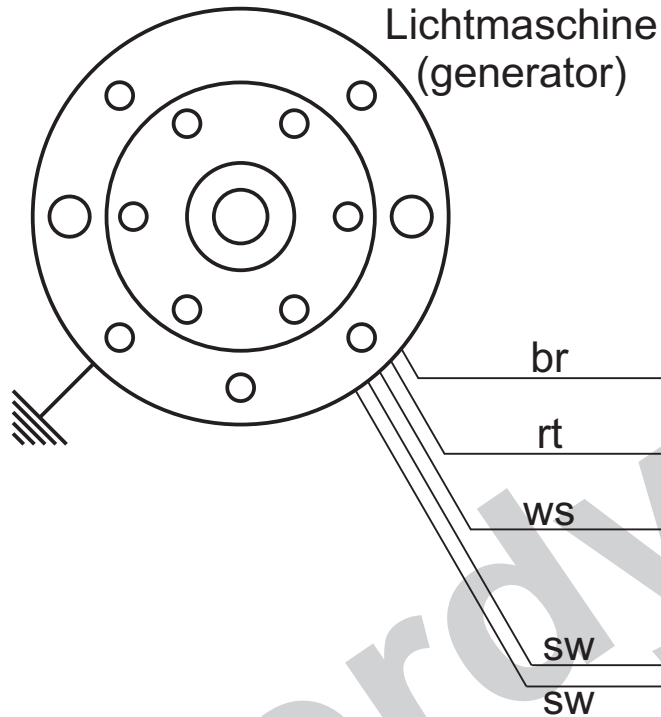

# Schaltplan 3-Zylinder (wiring diagram)

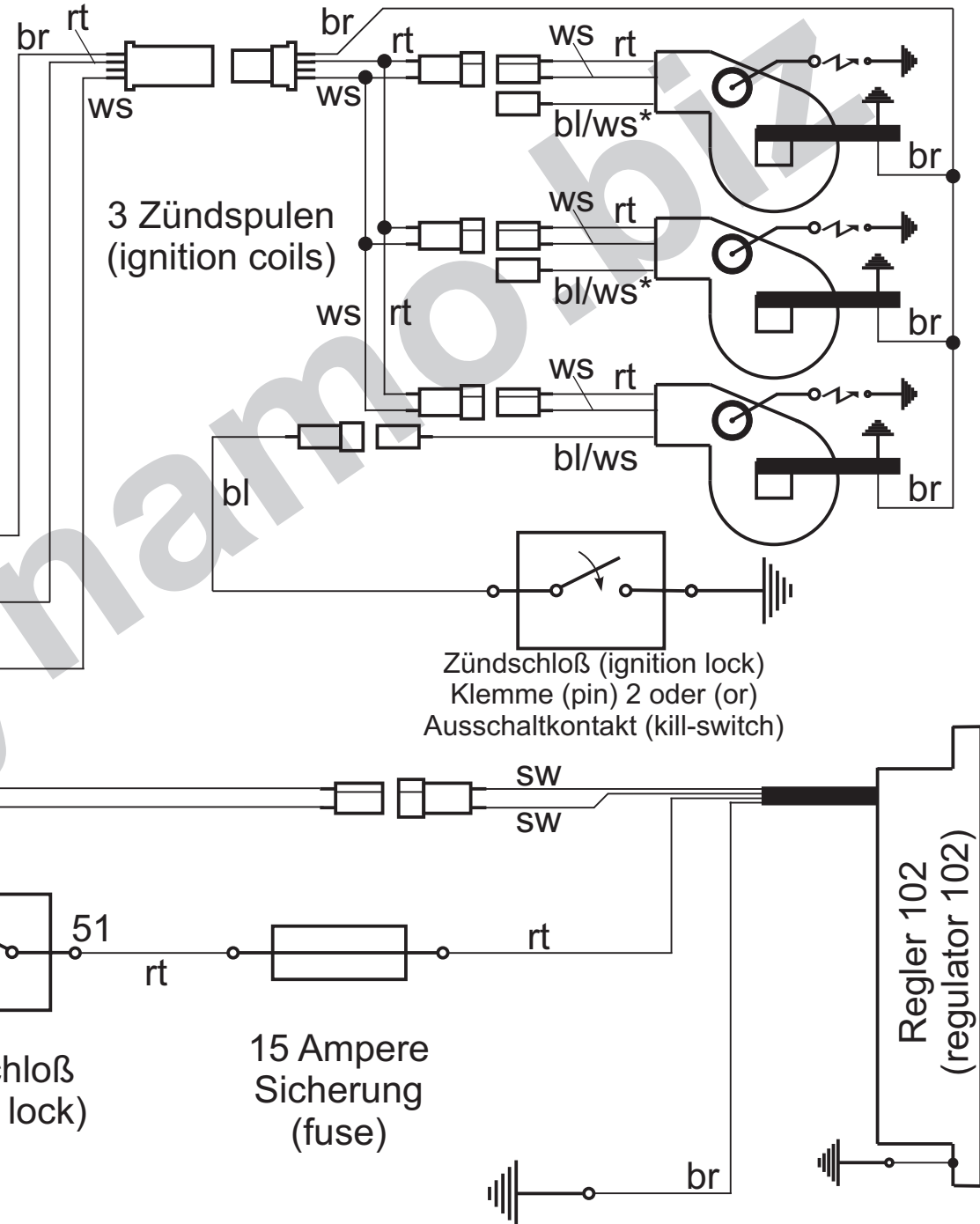

- Kabelfarben**  
(wiring colours):
- bl = blau (blue)
  - br = braun (brown)
  - ge = gelb (yellow)
  - gn = grün (green)
  - gr = grau (grey)
  - rt = rot (red)
  - sw = schwarz (black)
  - ws = weiß (white)



\* diese Kabel bleiben ungenutzt  
(\* these wires remain idle)

Bordnetz  
(existing electric system)